

CYCLOPS

LIGHTING

FLASH-88

44x20 watts RGBW Powerful
Light outdoor LED wash



USER MANUAL

Introduction

Packaging: Thanks for your purchasing the FLASH-88. All the lights have been checked and are in excellent operating condition. Please check the shipping carton first, because there may be damage occurred during the shipment. Then check the lights carefully and be sure that the lights is intact and works normally. In the event damage has been found, spare parts are missing or the lights works abnormally, please contact us for further instructions. And please don't return the lights to the dealer before contacting us.

Introduction: The FLASH-88 has three operating modes: DMX mode, Auto mode and Master/Slave mode. And the lights has five DMX modes, including channel 3, channel 4, channel 6, channel 8 and channel 11. There are twenty-one built-in Auto programs and you can see twenty-one kinds of shows when you open the Auto mode. Meanwhile, you can edit your desired Auto program in "EDIT" menu. In addition, you can connect several pieces of lights in DMX mode and set one in Auto mode, and the others in Master/Slave mode. And then all the lights in Master/Slave mode will run following the one in Auto mode. Using fog or special effect smoke, you can see better showing effect.

Warning!

1. Don't expose the lights to rain or moisture, for the sake of preventing the risk of electrical shock or fire.
2. Don't look directly at the opening lights all the time, or it may damage your eyes.

Product Overview

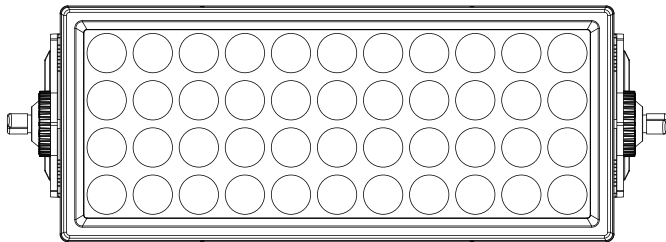

Connection

DMX connection

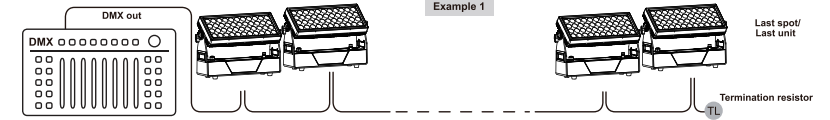

Master / Slave connection

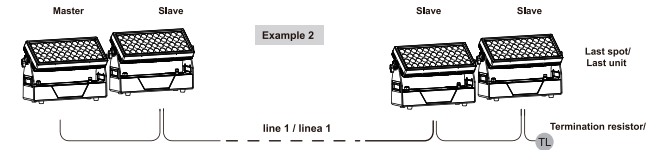

Wireless connection

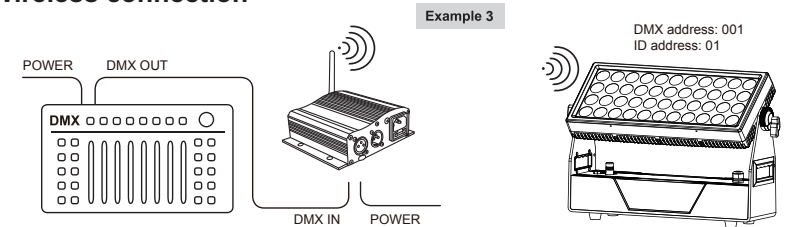

Press "ENTER" button and then "UP" or "DOWN" button until "SET UP" is showed.

Press "ENTER" button and then "UP" or "DOWN" button until "Wireless rel" is displayed, press ENTER button. Then press DMX Mode is ok.

Then, until Green wireless signal is displayed. Then Wireless DMX connected success.

About the condition of wireless signal, Green represents the successful setting, while red represents the signal is unsuccessful.

Release wireless DMX signal

Press "ENTER" button and then "UP" or "DOWN" button until "Wireless rel" is showed.

Press "ENTER" button and then "UP" or "DOWN" button until "press +/-" is displayed, press "UP" or "DOWN" button, long press "UP" or "DOWN" button about

5-6 seconds. Until "Initialization" to "Release finish" is displayed. It means release signal successfully.

CABLE CONNECTORS

Cabling must have a male XLR connector on one end and a female XLR connector on the other end.

DMX connector configuration

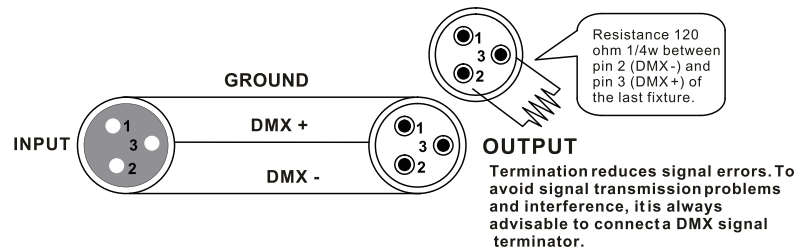

caution: Do not allow contact between the ground and the fixture's chassis ground. Grounding the ground can cause a ground loop, and your fixture may perform erratically. Test cables with an ohm meter to verify positive pole and to make sure the pins are not grounded or shorted to the shield or each other.

3-PIN TO 5-PIN CONVERSION CHART

Note! If you use a controller with a 5 pin DMX output connector, you need to use a 5 pin to 3 pin adapter. The chart below details a proper cable conversion:

Conductor	3 Pin Female (output)	5 Pin Male (Input)
Ground/Shield	Pin 1	Pin 1
Data (-) signal	Pin 2	Pin 2
Data (+) signal	Pin 3	Pin 3
Do not use		Do not use
Do not use		Do not use

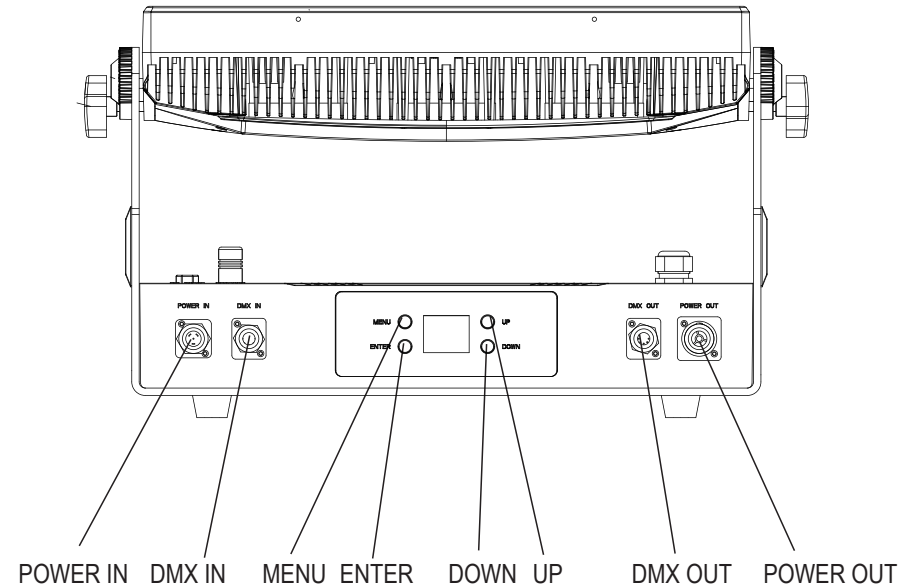

Mechanical Specification

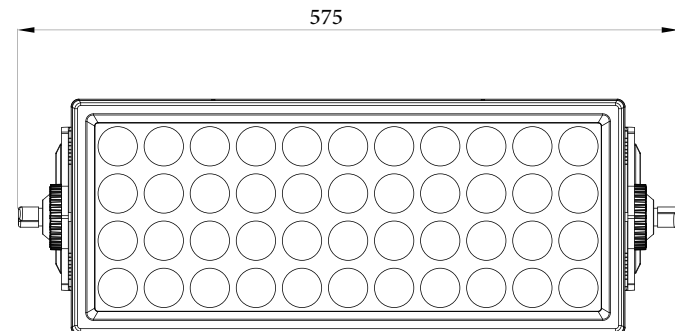

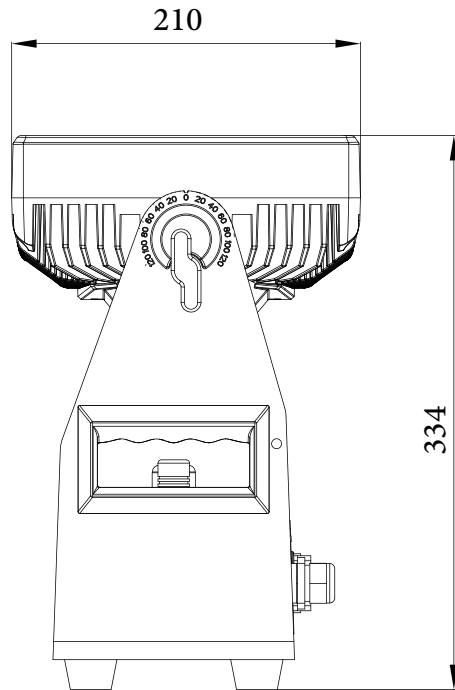

Channel 12 (Id address set)

0--9	all Ids
10--19	Id1
20--29	Id2
30--39	Id3
40--49	Id4
50--59	Id5
60--69	Id6
70--79	Id7
80--89	Id8
90--99	Id9
100--109	Id10
110--119	Id11
120--129	Id12
130--139	Id13
140--149	Id14
150--159	Id15
160--169	Id16

170--179	Id17
180--189	Id18
190--199	Id19
200--209	Id20
210	Id21
211	Id22
212	Id23
213	Id24
214	Id25
215	Id26
216	Id27
217	Id28
218	Id29
219	Id30
220	Id31
221	Id32
222	Id33

223	Id34
224	Id35
225	Id36
226	Id37
227	Id38
228	Id39
229	Id40
230	Id41
231	Id42
232	Id43
233	Id44
234	Id45
235	Id46
236	Id47
237	Id48
238	Id49
239	Id50

240	Id51
241	Id52
242	Id53
243	Id54
244	Id55
245	Id56
246	Id57
247	Id58
248	Id59
249	Id60
250	Id61
251	Id62
252	Id63
253	Id64
254	Id65
255	Id66

ACCESSORIES



DMX 9 channel

channel	value	function
1	0 - 255	Master dimmer
2	0 - 255	Dimmer speed
3	0 - 255	red
4	0 - 255	green
5	0 - 255	blue
6	0 - 255	white
7	0 - 255	Strobe
8	0 - 255	auto/ customer effect
9	0 - 255	speed

DMX 12 channel

channel	value	function
1	0 - 255	Master dimmer
2	0 - 255	Dimmer speed
3	0 - 255	red
4	0 - 255	green
5	0 - 255	blue
6	0 - 255	white
7	0 - 005	Strobe open
	006 - 010	Strobe closed
	011 - 033	Plus Random, slow -> fast
	034 - 056	Ramp up Random, slow -> fast
	057 - 079	Ramp down Random, slow -> fast
	080 - 102	Random Strobe Effect, slow -> fast
	103 - 127	Strobe Break Effect, 5s..... 1s(Short burst with break)
	128 - 250	Strobe slow -> fast < 1Hz - 20Hz
251 - 255	Strobe open	
8	0 - 255	72 color
9	0 - 255	11 white
10	0 - 255	auto effect
11	0 - 255	speed
12	0 - 255	ID

Features**SOURCE**

Light source: 44 x 20 watts, RGBW LEDs
 LED life expectancy: 50,000 Hrs
 CRI <80

OPTICAL SYSTEM

Beam angle: 20°
 40° with a magnetic diffuser filter
 Light output: 85,000 Lux @ 2m @ 30°

DYNAMIC EFFECTS

Dimmer: 4 selectable dimming curves
 Color mixing: RGBW
 Strobe effect
 Built-in color and dynamic macros

CONTROL & PROGRAMMING

Control protocols: DMX, RDM, W-DMX™ by Wireless Solution
 Display: OLED graphical display with 4 buttons
 Control channels: 2, 3, 4, 9 & 12 CHs

ELECTRICAL

Input voltage: 190-264V/50-60Hz
 Power consumption: 880 watts
 Power supply: Auto-ranging electronic switch-mode

CONNECTIONS

DMX connections: 3 pin XLR In/Out male and female
 Power connections: IP Powercon In/Out

PHYSICAL

Dimensions: 575 x 210 x 334mm
 Net weight: 15.7 Kg
 Color: Black
 Housing: Die-cast Aluminum
 IP rating: 65
 Operating temperature: -40°C/50°C

Displayer introduction

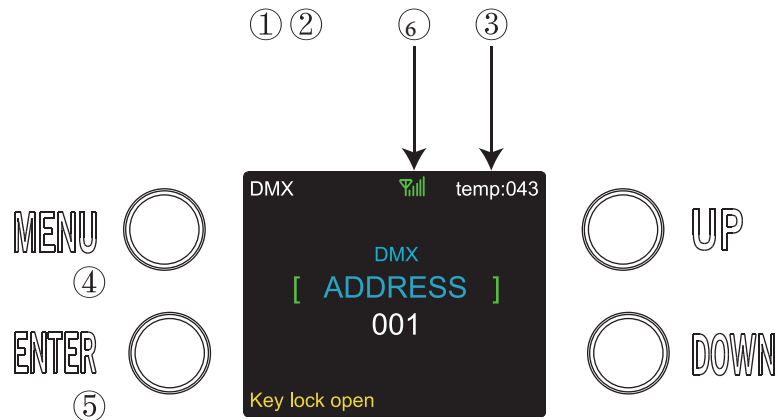

1. DMX means the light is in the DMX mode. Similarly, SLAVE means the light is in the SLAVE mode.
2. The color of the point shows the condition of signal transmission. Green represents the good condition, while red represents the signal is interrupted.
3. The item shows the working temperature of the light. When the working temperature exceeds the max temperature, the color of the letters and number will change from white to yellow.
4. This item shows the menu you selected.
5. This item shows the condition of key lock. "Key lock open" means the key lock is open. And "Key lock off" means the key lock is close.
6. The color of the point shows the condition of wireless signal. Green represents the good condition, while red represents the signal is interrupted.

DMX control mode

DMX 2 channel

channel	value	function
1	0 - 255	72 color
2	0 - 255	11 kinds of white

DMX 3 channel

channel	value	function
1	0 - 255	Hue
2	0 - 255	Saturation
3	0 - 255	Value(brightness)

DMX 4 channel

channel	value	function
1	0 - 255	red
2	0 - 255	green
3	0 - 255	blue
4	0 - 255	white

AUTO-In this menu, you can select your desire AUTO mode and adjust the running speed.

1. Press “ENTER” button and then UP or DOWN button until “AUTO” is showed.
2. Press “ENTER” button, and “SPEED” or “AUTO MODE” will be showed. Then press ENTER,and you can see two items as below:
 - 1) SPEED - You can select your desired speed in this menu.
 - 2) AUTO MODE - You can select your desired auto mode in this menu.

CUSTOMER-In this menu,you can select the AUTO program edited in the “EDIT” menu.

1. Press “ENTER” button and then UP or DOWN button until “CUSTOMER” is showed.
2. Press “ENTER” button, and there are 11 pre-programmed mode edited in the “EDIT”menu.

CAL WHITE-In this menu, you can adjust the value of 11 different white color.

1. Press “ENTER” button and then UP or DOWN button until “CAL WHITE” is showed.
2. Press “ENTER” button, and there are 11 pre-programmed White colors that can be edited by adjusting the value of “Red”, “Green”, “Blue” and “White”

STAT COLOR-In this menu, you can adjust the value of static color and strobe speed as you like.

1. Press “ENTER” button and then UP or DOWN button until “STAT COLOR” is showed.
2. Press “ENTER” button, and there are six options. Then press ENTER to select the option and press UP or DOWN button to select the value you desire as below:
 - 1) STAT RED - You can adjust the red brightness in this menu.
 - 2) STAT GREEN - You can adjust the green brightness in this menu.
 - 3) STAT BLUE - You can adjust the blue brightness in this menu.
 - 4) STAT WHITE - You can adjust the white brightness in this menu.
 - 5) SELET COLOR -You can select 52 static color in this menu.
 - 6) STAT STROB - You can adjust the strobe speed in this menu.

EDIT-In this menu, you can edit your desired AUTO program.

1. Press “ENTER” button and then UP or DOWN button until “EDIT” is showed.
2. Press “ENTER” button, and open the “EDIT” mode to edit the custom programs from“PR.01” to “PR.11”.And there are 32 scenes that can be edited in each custom program.
3. You can edit a scene by adjusting the value of “RED (0~255)”, “GREEN (0~255)”, “BLUE (0~255)”, “WHITE (0~255)”, “FADE (0~31)”, “FLASH(0~50)”, “STROBE (0~31)” & “TIME (0~100)” as you like. Then the data will be saved, when you press the ENTER button for 5 seconds.

UPLOAD-In this menu,you can connect several pieces of lights with MAX cables and set one light as the MASTER and others in SLAVE mode.Then upload the custom program in the MASTER light to the lights in SLAVE mode.

1. Press “ENTER” button and then UP or DOWN button until “UPLOAD” is showed.
2. Press “ENTER” button to upload the custom programs from the MASTER light to the SLAVE ones.

RESET-In this menu, you can reset all the value of the system.

1. Press “ENTER” button and then UP or DOWN button until “RESET” is showed.
2. Press the ENTER button to reset all the value of the system.

Programme Menu

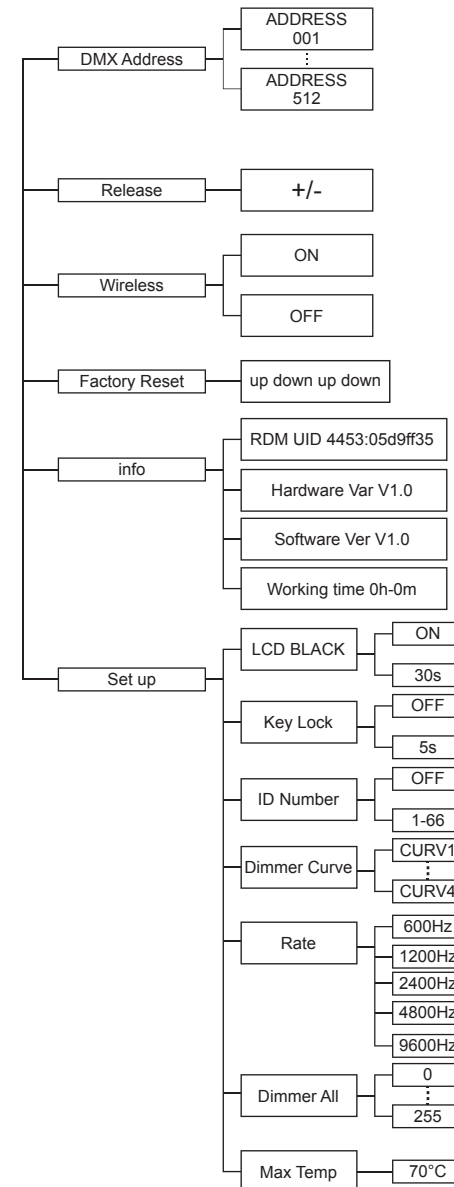

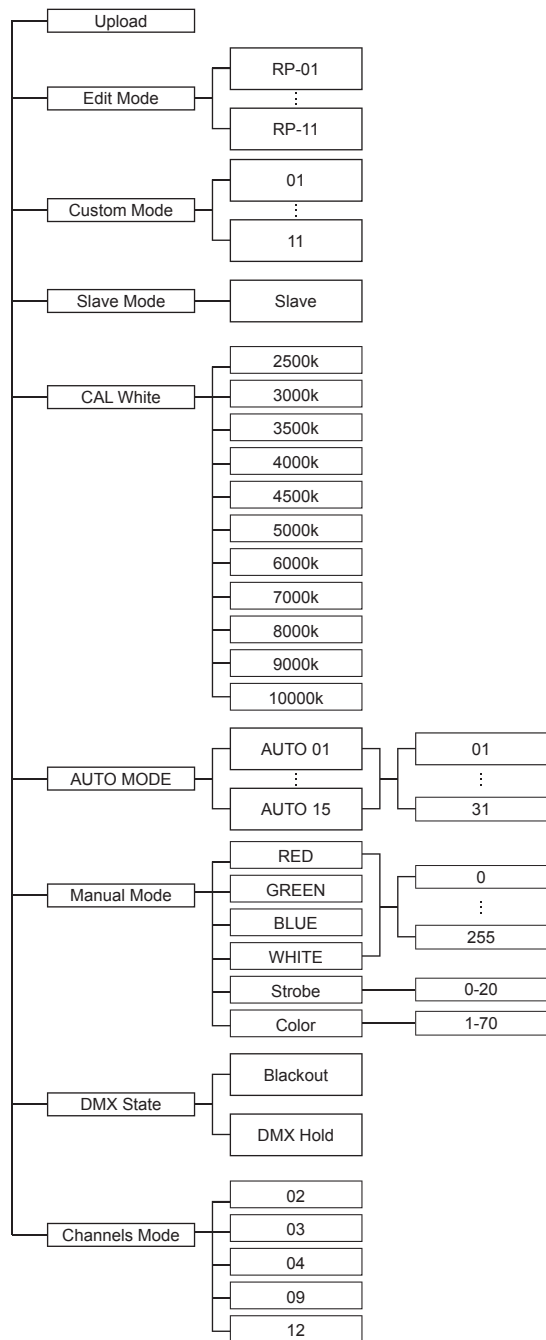

Operation

DMX-In this menu, you can connect several pieces of lights with DMX cable and control them with control console.

1. Press “ENTER” button and then UP or DOWN button until “DMX ” is showed.
2. Press “ENTER” button, and “CHANNEL” or “ADDRESS” will be showed. Then press ENTER.
 - 1) “Channel [xx]” will be showed, “X” represents the showed DMX channel mode. You can press the UP or DOWN button to select your desired Channel mode.
 - 2) “xxx” will be showed, “x” represents the showed address. You can press the UP or DOWN button to select your desired address.

RUN MODE-In this menu, you can select DMX mode or SLAVE mode. In SLAVE mode, you can select one light as the MASTER light and other lights in SLAVE mode will run following the MASTER light.

1. Press “ENTER” button and then UP or DOWN button until “RUN MODE” is showed.
2. Press “ENTER” button, and “DMX” or “SLAVE” will be showed, then press ENTER to select your desired mode.

SET UP-In this menu, you can adjust the value of the function.

1. Press “ENTER” button and then UP or DOWN button until “SET UP” is showed.
2. Press “ENTER” button, and there will be nine options. Then, press ENTER to select the option and press UP or DOWN button to select the value you desire as below.
 - 1) ID number - You can select an ID Number in this menu. Then, you can adjust the value of channel 11 to the corresponding scope and control the light individually with control console.
 - 2) Display Led - In this item, you can select “ON” or “OFF”. If you select ON, the display will be on all the time. And if you select OFF, the display will extinguish about ten seconds later.
 - 3) Key locks - You can select whether the password is on or off in this menu, and the password is [DOWN] + [UP] + [DOWN] + [UP]. If you select “on”, then you have to input the password before pressing the buttons. Otherwise, the light won’t respond to your order.
 - 4) Max temp - You can set your desired Max working temperature about the light in this menu. When the working temperature of the light exceeds the Max temperature, the color of letter “Temp xx” showed in the menu will change from white to yellow. Meanwhile, the light will adjust the working temperature automatically.
 - 5) Dimmer RED - You can adjust the red brightness in this menu.
 - 6) Dimmer GREEN - You can adjust the green brightness in this menu.
 - 7) Dimmer BLUE - You can adjust the blue brightness in this menu.
 - 8) Dimmer WHITE - You can adjust the white brightness in this menu.
 - 9) Dimmer ALL - You can adjust the brightness of each color in this menu.
 - 10) Wireless rel - You can set the control of wireless setting.

INFORMATION-In this menu, you can learn about the information of software, hardware and the working time of the light.

1. Press “ENTER” button and then UP or DOWN button until “INFORMATION” is showed.
2. Press “ENTER” button, and “Software” “Hardware” or “Fix times” will be showed. Then press ENTER, and you can see three items as below:
 - 1) Software - This item displays the Software information.
 - 2) Hardware - This item displays the Hardware information.
 - 3) Fix times - This item displays the working hours about the light.